

Virginia Tech Climate Action Commitment & Sustainability Plan

Background

- In April 2008, President Charles Steger charged the university Energy & Sustainability Committee (E&SC) to develop a Climate Action Commitment and Sustainability Plan specific to Virginia Tech, and to complete governance review of the plan by Spring 2009
- The E&SC established the VTCAC & SP Subcommittee.
- The draft VTCAC & SP was developed throughout the Summer and 2008 Fall Semester.
- Navigation through the university's governance system throughout the Spring of 2009.
- Virginia Tech Board of Visitors unanimously approves the VTCAC Resolution on June 1, 2009.

The VTCAC Resolution

- The VTCAC Resolution contains 14 items including:
 - Being a leader in campus sustainability.
 - Representing the VTCAC&SP in the Strategic Plan.
 - Setting targets for the reduction of GHG emissions to 80% below the 1990 level by 2050 with interim targets.
 - Establishing the Office of Sustainability
 - Pursuing LEED Silver certification or better and exceeding ASHRAE 90.1 2007 energy performance by 30%.
 - Adopting a goal of 35% recycle rate by 2012.
 - Implementing the VTCAC&SP subject to the availability of funds.

The VTCAC & SP

- Large report covering all aspects of the University from facilities to academics to behavior & campus life
- Builds on an energy and greenhouse gas (GHG) emission inventory completed by students in 2008
- Recognizes that solutions to campus energy and emissions, also save precious dollars spiraling out of control for utilities:

“Save the University, Save the Planet!”

Distribution of VT GHG Emissions

Figure 8. Virginia Tech campus GHG emissions, 2000-2006

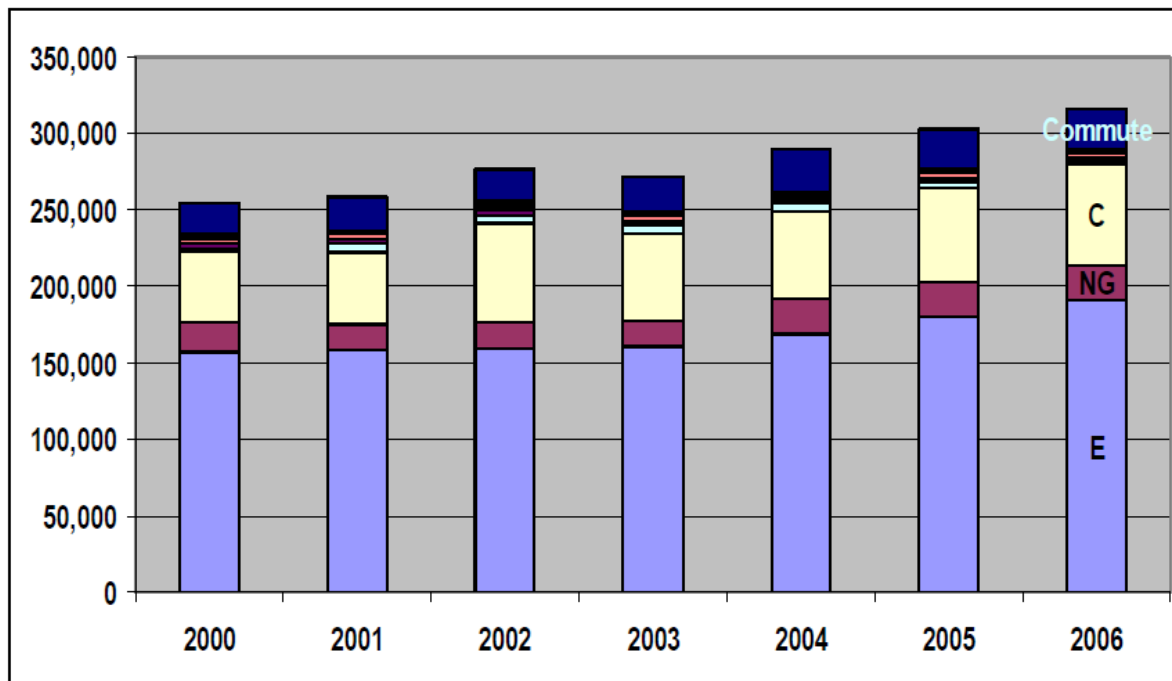
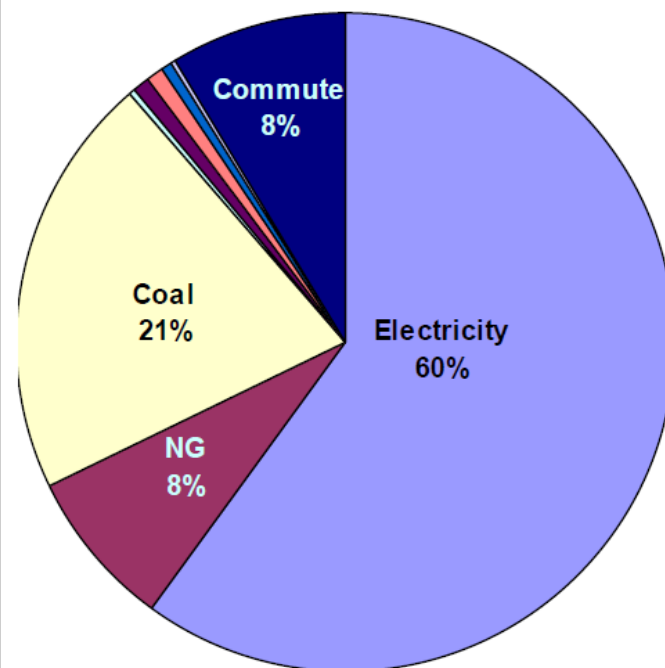
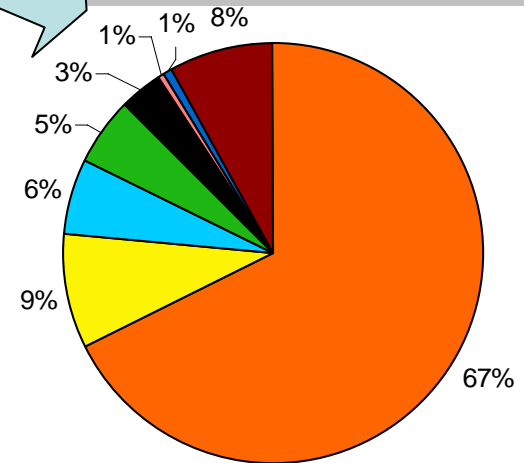
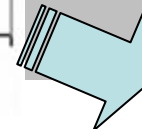
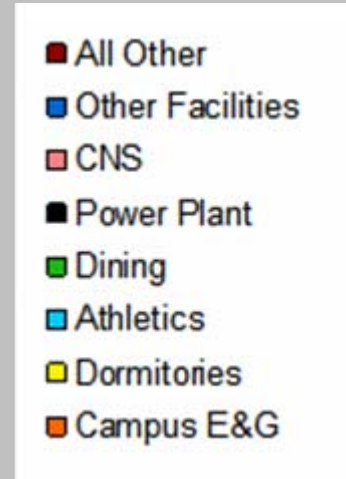
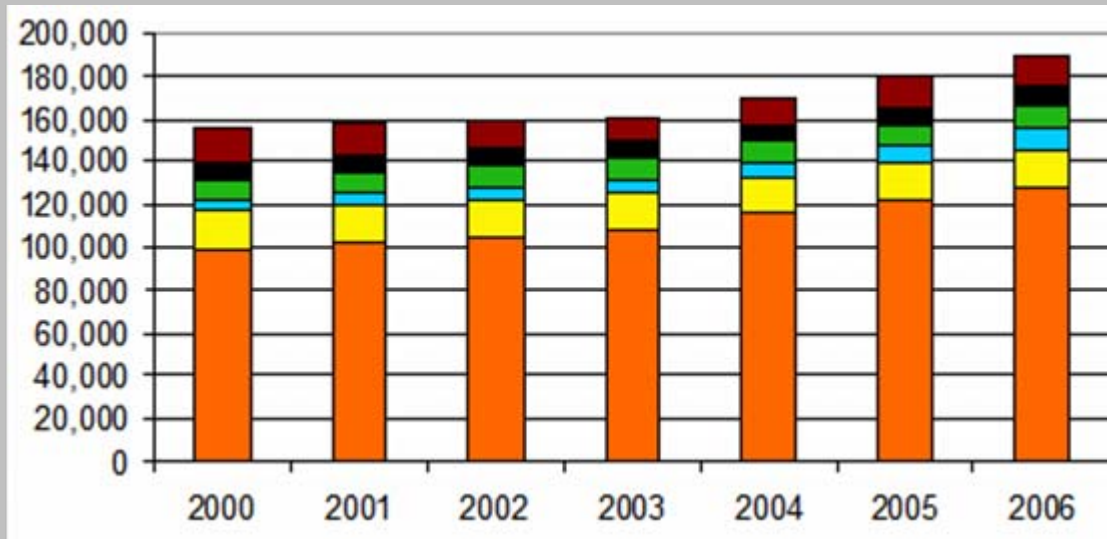

Figure 9. 2006 VT campus GHG emissions



Virginia Tech Electricity Use

Tons CO₂-e



- Includes electricity purchased from AEP and generated at Central Steam Plant
- Most consumption is in educational buildings and general facilities (Campus E&G)
- Athletics department electricity use increased rapidly 2004-2006

VTCCAC & SP: Prospective Actions

- Immediate (2009-2012)
- Midterm (2013-2025)
- Long-term (2026-2050)

VTCAC & SP: Six Major Categories

1. Administrative Structure and Governance
2. Facilities Infrastructure
3. Facilities Operation
4. Transportation
5. Behavior and Campus Life
6. Academic Programs

Facilities Operations

- Thermostat settings, air handling, and chiller operation
- Virginia Tech Recycling (VTR)
- Smart Procurement

Energy Conservation – Temp Setback

Steam Send-Out Results

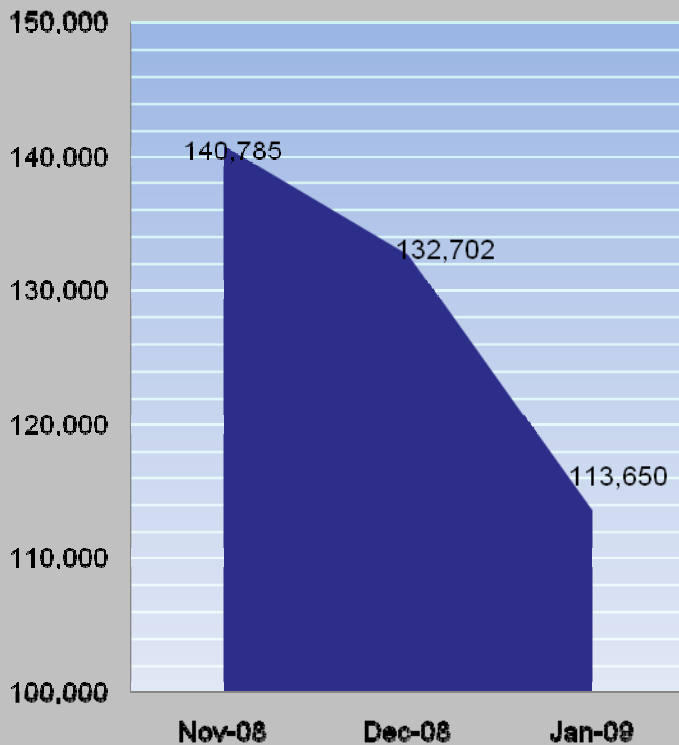

	Nov-08	Dec-08	Jan-09
■ Monthly lbs/HDD	140,785	132,702	113,650

- Steam send out Reduction:
 - Dec 5.7%
 - Jan 19.3 %
- HDD Analysis
 - Dec 849 HDD
 - Jan 1,052 HDD
- Calculated Savings:
 - Dec 6,456 Mlbs
 - Jan 23,075 Mlbs

Energy Conservation – AHU Shutdowns

- Target 23 buildings on campus:
 - 136 Air Handler Units
 - 1,961 HP of supply fan
 - 553 HP of exhaust fan
 - 1,876 total Kilowatt
- Based on our calculations this initiative has saved \$137,000 since its phased-in inception in 5/09
 - 60% savings from driving fan motors
 - Remaining savings is thermal savings across coil
 - Over 1 million kWh saved for driving fan motors
- Annual Potential for Present Program:
 - Additional buildings to be added
 - The shutting off of fan motors will result in over 3 million kWh reduced (\$286k)
 - Additional \$80k in cooling cost savings during season
 - Seasonal heating savings estimate being developed

Energy Management – Chilled Water

- Free Cooling maximized to produced a YTD reduction of:
 - 670K ton-hours
 - Or ~ 250,000 KWH
- Chiller Loop Temperature Slip:
 - Initial results indicate a 5% reduction in peak electrical demand at the plant may be possible without impacting clients

Facilities Infrastructure

- Central Heat and Power Plant and Steam Distribution System
- Virginia Tech Utilities
- The Chiller System
- New and Renovated Buildings
- Existing Buildings
- Campus Planning, Landscape and Grounds

Steam Infrastructure Project Nearing Completion

WORK / BID PACKAGE	DESCRIPTION OF WORK	STATUS
WP1	Steam Distribution Repairs	95% Complete
WP2	Summer Steam Condenser	100% Complete
WP3	Steam Distr. System Upgrades – Bridge work at Turner/Stanger (by Owner)	100% Complete
BP1	Steam Distribution System Upgrades	100% Complete
BP2	Boiler 8, 9, 10 Upgrades	100% Complete
BP3	Plant Upgrades, Phase 1 (Demineralizer, Dearator and Atemporator)	100% Complete
BP4	Coal Yard Cover	Deferred
BP5	Plant Upgrades, Phase II (Equipment)	RFP
	Plant Upgrads Phase II (Installation)	Planning
BP6	Life Sciences Steam Lines	48% Complete
BP7	North Campus Steam Lines	Planning
CNS		90% Complete
TOTAL	Campus Heat Plant Upgrades	75% Complete

Utility Master Planning – Steam

- Current plant upgrades provide installed capacity of 440,000 lbs/hr
 - Largest boiler is 100,000 lbs/hr
 - N+1 capacity is 340,000 lbs/hr
- Current Peak load is approximately 260,000 lbs/hr
- Total GSF by 2015
8,343,200
- Current steam capacity and infrastructure upgrades can provide for ~9,792,000 GSF

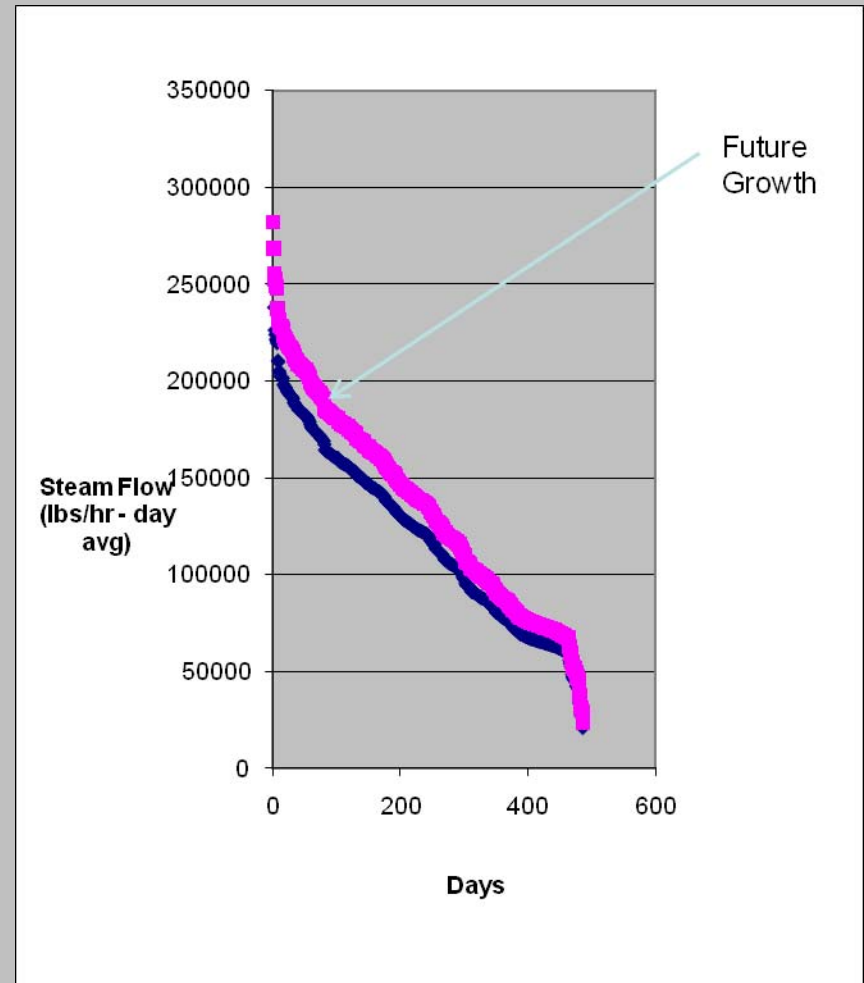

Energy Management – Power Plant

- Other central steam plant equipment investments included:
 - The installation of new equipment in gas fired boilers including new economizers, new firing controls and new low NO(x) burners
 - Annual savings are approximately \$400,000 per year based on then-current fuel costs
- Currently preparing SCADA engineering RFP to establish centralized Operational Control Center for total utility oversight and management

ESCO's – VT Potential Summary

Phase	NO of Buildings	Gross SgFt	Cost (million)	Potential GHG Reduction	Target Date
1	6	737,035	\$11.5	2.5%	2011
2	12	1,649,256	\$9.0	2.5%	2012
3	25	2,003,636	\$13.0	5.0%	2014
4	19	1,321,542	\$12.0	5.0%	2016

Potential GHG reduction of 15% or in range of 53 tons as expressed in VT Climate Action Commitment estimate for 2012 if no action taken ????

Electricity use per ft², Building Type

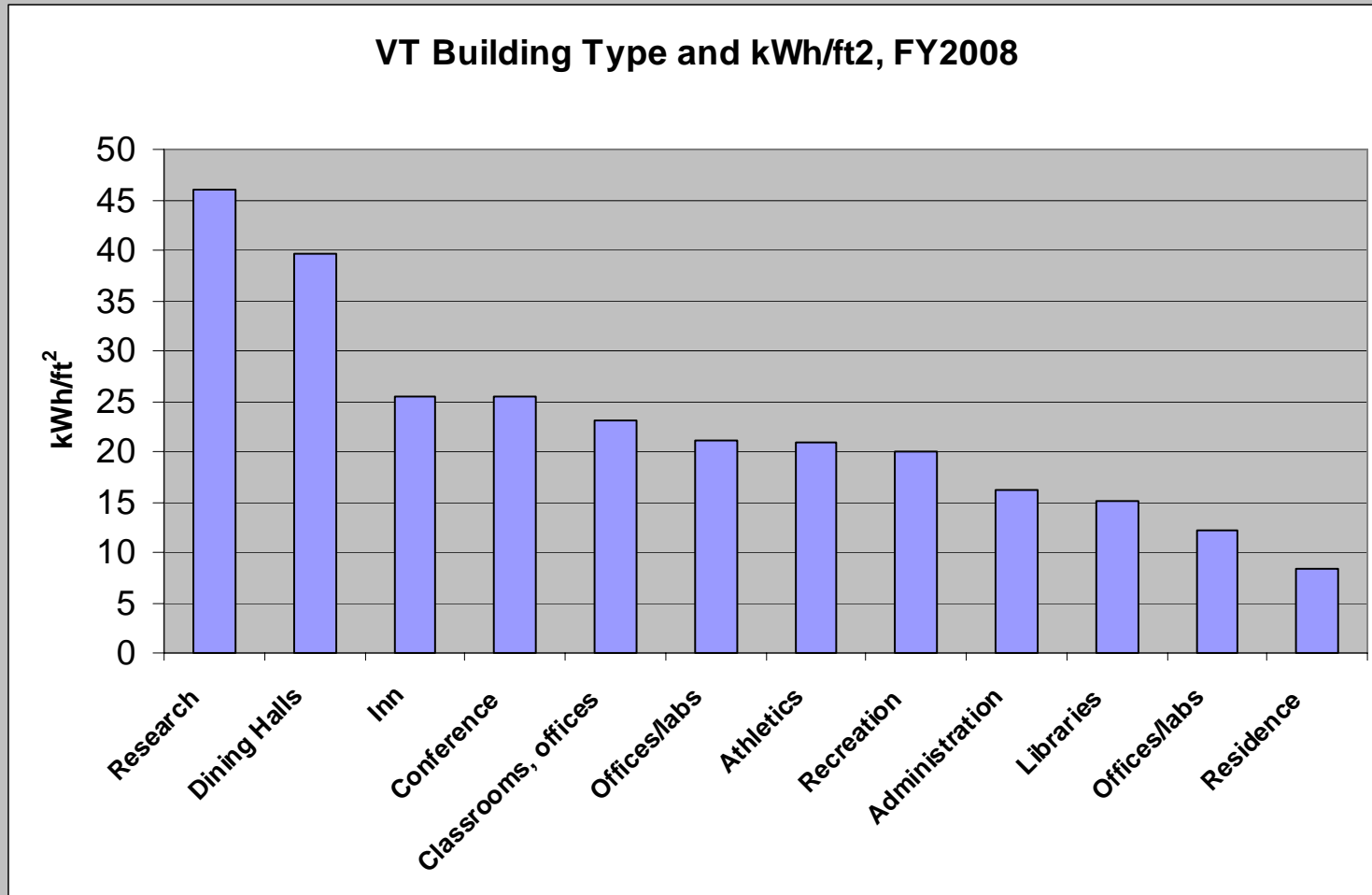

Virginia Tech Guaranteed Energy Savings Project



March 26, 2009

Virginia Tech Guaranteed Energy Savings Project



Laboratory/Research –
Hahn Hall: 71,106 GSF 1988



Academic/Administration –
McBryde Hall 132,244 GSF 1971



Dinning –
Dietrick Hall: 92,907 GSF 1970

Virginia Tech Guaranteed Energy Savings Project



**Dormitory –
Pritchard Hall: 211,481 GSF 1967**



**Athletics –
Cassell Coliseum: 187,000 GSF 1963
Jamerson Center: 39,617 GSF 1984**



Main Power/Steam Plant

Project Environmental Impact

- 27.1 M lbs of CO₂ Reduction

Environmental Impact Chart

	Before	After	Saved
Pounds Carbon Monoxide	1,103,169	1,100,360	2,809
Pounds Carbon Dioxide	5,420,305,483	5,393,189,630	27,115,854
Pounds Lead	2.0	1.1	1.0
Pounds Mercury	0.7	0.4	0.3
Pounds Nitrous Oxide	6,851,226	6,825,742	25,484
Pounds PM10	123,619	122,190	1,428
Pounds Sulfur Dioxide	972,574	906,694	65,881
Pounds Volatile Organic Compounds	244,112	243,761	351
Cars & Light Trucks Off The Road	542,031	539,319	2,712
Barrels of Oil	5,691,321	5,662,849	28,472
People Reducing Energy Use By 20%	2,710,153	2,696,595	13,558
Acres of Forests Absorbing Carbon	2,439,137	2,426,935	12,202
Tons of Waste Recycled	813,046	808,978	4,067

Estimation is calculated on EPA source data.

Annual Equivalent Impact:

- 28,472 Barrels of Oil
- 12,202 Acres of Forest

Energy Conservation Measures Reviewed

Cost Savings Summary By ECM				
ECM	Description	Savings	Costs	Simple Payback (Years)
1	Lighting	\$ 85,632	\$ 538,639	6.29
2	HVAC Controls	\$ 98,626	\$ 267,043	2.71
3	Demand Control Ventilation	\$ 6,978	\$ 3,576	0.51
4	Steam Control	\$ 1,875	\$ 34,328	18.31
5	Economizer	\$ 25,288	\$ 75,808	3.00
6	Water Conservation	\$ 19,998	\$ 71,166	3.56
7	Domestic Hot Water Decentralization	\$ 36,991	\$ 706,341	19.09
8	Variable Frequency Drives Upgrades	\$ 18,337	\$ 480,978	26.23
9	Steam System Repair	\$ 49,651	\$ 119,504	2.41
10	Electric Motor Replacement	\$ 4,297	\$ 166,584	38.77
11	Fume Hood Efficiency Upgrades	\$ 188,932	\$ 2,328,815	12.33
12	Ventilation Energy Recovery	\$ 39,955	\$ 346,362	8.67
13	Variable Pumping Applications	\$ 18,997	\$ 107,718	5.67
14	Main Kitchen Hood Ventilation Upgrades	\$ 85,486	\$ 157,558	1.84
15	Food Court Hood Ventilation Upgrades	\$ 50,792	\$ 580,872	11.44
16	Cooling Tower Upgrades	\$ 21,178	\$ 13,409	0.63
17	Cooling Tower Water Treatment	\$ 6,609	\$ 109,492	16.57
18	Solar PV System	\$ 6,988	\$ 771,549	110.41
19	Energy Recovery	\$ -	\$ -	-
20	Wind Turbine	\$ 52,450	\$ 1,524,733	29.07
21	Compressed Air Decentralization	\$ -	\$ -	-
22	Windows	\$ 24,464	\$ 105,056	4.29
23	Destratification Fans	\$ 2,051	\$ 7,595	3.70
24	Vending Miser	\$ 2,443	\$ 10,070	4.12
25	Transformers	\$ 15,340	\$ 279,794	18.24
26	Kitchen Appliance Replacement	\$ 63,655	\$ 286,066	4.49
27	Boiler Blowdown Recovery	\$ 51,954	\$ 82,866	1.59
28	Sensible Attemperators	\$ 94,348	\$ 482,737	5.12
29	Absorption Chiller	\$ 177,267	\$ 2,882,432	16.26
30	Powerhouse VFD Upgrades	\$ 108,688	\$ 750,781	6.91
31	Automatic Compressors Staging	\$ 7,578	\$ 71,517	9.44
32	Recover Heat from compressors	\$ 18,157	\$ 50,062	2.76
33	Compressor Water Shutoff	\$ 150	\$ 1,716	11.42
34	Install Anaerobic Digester	\$ 23,055	\$ 3,575,828	155.10
35	Energy Awareness	\$ 23,734	\$ 35,758	1.51
36	Metering	\$ -	\$ 64,365	-
37		\$ -	\$ -	-
TOTAL PROJECT		\$ 1,431,943	\$ 17,091,119	11.94

ECM 1 – Energy Efficient Lighting

- Replacing existing 34 watt and 32 watt lamps
- Delamping over illuminated areas
- Replace existing incandescent lamps
- Replace HID Fixtures
- Install Occupancy Sensors
- Daylighting Controls
- Skylight Installation in Cassell
- Standardized lighting system



Annual ECM Savings: \$85,632

Buildings Impacted:

McBryde Hall
Hahn Hall
Pritchard Hall
Dietrick Hall
Cassell Coliseum
Power House

ECM 2 – HVAC Controls

- Hot Water Reset
- Equipment and Space Temperature Set-point Scheduling
- Supply Air Temperature Reset
- Installation of Thermostatic Control Valve



Annual ECM Savings: \$98, 626

Buildings Impacted:

McBryde Hall
Hahn Hall
Pritchard Hall
Dietrick Hall
Cassell Coliseum

ECM 3 – Demand Control Ventilation

- Installation of carbon dioxide sensors
- Heating and cooling of excess outdoor air will be eliminated

Buildings Impacted:
McBryde Hall



Annual ECM Savings: \$6,978

ECM 4 – Steam Control

- Install Control Valves
- Install Programmable Thermostat



Annual ECM Savings: \$1,875

Buildings Impacted:
Cassell Coliseum

ECM 5 – Economizer

- Outdoor Air Temperature and Humidity Monitoring
- Installation of control points and dampers - Cassell
- Reprogramming controls system - McBryde



Annual ECM Savings: \$25,288

Buildings Impacted:
McBryde Hall
Cassell Coliseum

ECM 6 – Water Conservation

- Install New Toilets and Flush Valves
- Install New Urinal Flush Valves
- Install Sink Flow Controls

Buildings Impacted:

McBryde Hall
 Hahn Hall
 Pritchard Hall
 Dietrick Hall
 Cassell Coliseum

Building	Commercial High Flow Diaphragm Valve Toilets to Replace with 1.6 gpf China and Piston Valve	Urinal Valves Proposed to Replace	Lavatory Faucets to Retrofit with 0.5 gpm Flow Controls
Cassell Coliseum	6	0	15
McBryde Hall	0	0	56
Pritchard Hall	35	10	20
Dietrick Hall	4	0	28
Hahn Hall	1	0	19
TOTALS	46	10	138

Annual ECM Savings: \$19,998

ECM 8 – Variable Frequency Drive Upgrades

- AHU Applications
- Fan Energy Reduction
- Reduces Motor Inrush Current and Cycling
- Extends Motor Life

Buildings Impacted:

McBryde Hall
Cassell Coliseum



Annual ECM Savings: \$18,337

ECM 9 – Steam System Repair

- Steam Valve and Fitting Repairs and Replacement
- Pipe Insulation Repairs and Replacement
- Steam Trap Replacement
- Insulate Receivers and Tanks



Buildings Impacted:

McBryde Hall
Hahn Hall
Pritchard Hall
Dietrick Hall
Cassell Coliseum
Power House

Annual ECM Savings: \$49,651

ECM 10 – Electric Motor Replacement

- Replace Existing Low Efficiency Motors
- Saves Energy and Reduces Maintenance
- Longer Motor Life



Annual ECM Savings: \$4,297

Buildings Impacted:

Hahn Hall
Power House

ECM 11 – Fume Hood Efficiency Upgrades

- Convert Current Constant Volume System To Variable Air Volume
 - Reduced Exhaust Air
 - Reduced Make-up Air
- Remove Individual Fume Hood Exhaust Fans
 - Energy and Maintenance Savings



Buildings Impacted:
Hahn Hall

Annual ECM Savings: \$188,932

ECM 12 – Ventilation Energy Recovery

- Reduces Steam Requirement
- Transfers heat from Exhaust Air to Supply Air
- Install Heat Recovery Coils in Exhaust Plenum
- Install Pump and Piping for Glycol Solution
- Install Heat Recovery Coils on AHUs 1,5

Buildings Impacted:
Hahn Hall



Annual ECM Savings: \$39,955

ECM 13 – Variable Pumping Applications

- Reduce Energy Consumed for Pumping
- Delivers Chilled Water According to Load
- Install Variable Frequency Drives
- Replace three-way valves w/ two position valves

Buildings Impacted:

Hahn Hall
Dietrick Hall



Annual ECM Savings: \$18,997

ECM 14 – Main Kitchen Hood Ventilation Upgrades

- Install Make-up Air Unit
- Outside Air Reduction for Dining Area Units
- VAV exhaust and makeup



Annual ECM Savings: \$85,486

Buildings Impacted:
Dietrick Hall

ECM 15 – Food Court Hood Ventilation Upgrades

- Replace Existing Hoods with Make-up Island Type Hoods
- Install Four Make-up Air Units
- VAV exhaust and makeup

Buildings Impacted:
Dietrick Hall



Annual ECM Savings: \$50,792

ECM 16 – Cooling Tower Upgrades

- Condenser Water Reset
 - Replace Cooling Tower Motor
 - Install VFD
 - Improved Chiller Efficiency
- Install Sewer Deduction Meter

Buildings Impacted:
Dietrick Hall



Annual ECM Savings: \$21,178

ECM 22 – Window Upgrades

- Window Film Installation
 - Low-Emissivity Film
 - Reduce Solar Heat Gain
 - Reduce Glare
 - Block 99% UV Radiation
 - Improved Comfort

Buildings Impacted:

McBryde Hall

Dietrick Hall

Cassell Coliseum



Annual ECM Savings: \$24,464

ECM 26 – Kitchen Appliance Replacement

- Replace Select Appliances
 - Fish Ovens (Biscuit)
 - Install Gas Fired Oven
 - Hobart FT-800 Dishwasher
 - Install Hobart FT-900 Dishwasher
 - Investigate Potential Downsizing Dishwasher
 - Hobart UW50 Pot Washer
 - Install new Hobart UW50 Pot Washer
- Additional Appliance Opportunities



Buildings Impacted:
Dietrick Hall

Annual ECM Savings: \$63,655

ECM 29 – Absorption Chiller

- “Free” 15-psig steam available from mid-May to early October
- Average steam condensing rate of 24,000 lbs/hr
- Enough to support 1200-ton Absorption Chiller
- Annual Electric Energy Savings : 2.4 Million kWh (based on 148 days/yr Operation)

Buildings Impacted:
Power House

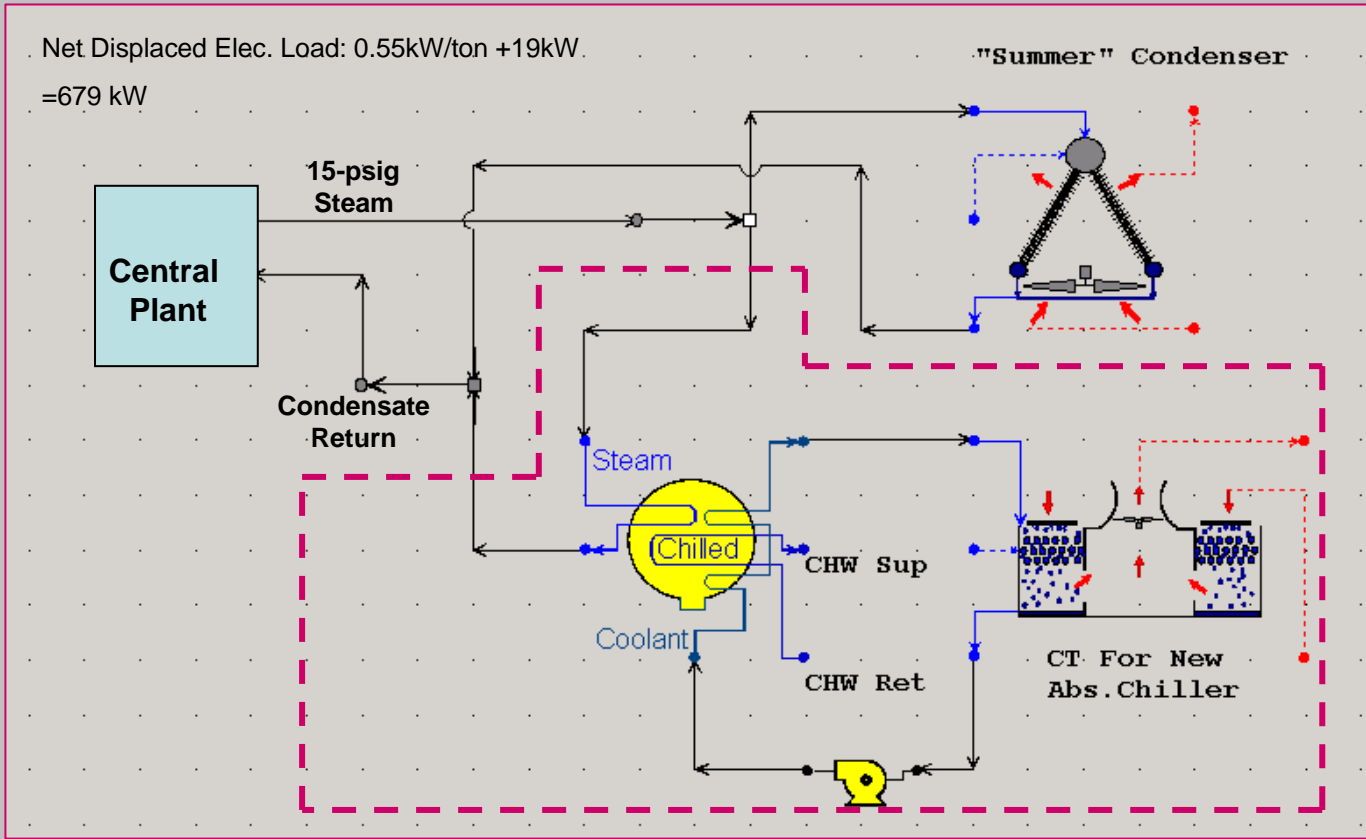

ECM 30 – Powerhouse VFD Upgrades

- Boiler No. 7 FD, OF, and ID Fans
- High Pressure Feed Water Pumps
- DA HW and Transfer Pumps
- DHW Pumps
- Ash Blower System

Buildings Impacted:
Power House

Annual ECM Savings: \$108,688

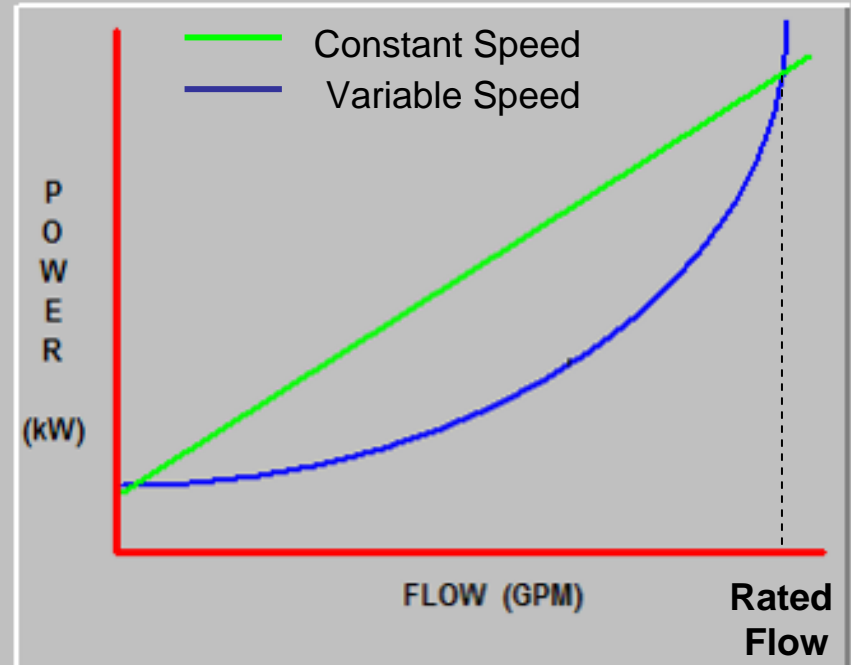

$$\begin{aligned} Power_2 &= Power_1 \times \left(\frac{RPM_2}{RPM_1} \right)^3 \\ &= Power_1 \times \left(\frac{Flow_2}{Flow_1} \right)^3 \end{aligned}$$

ECM 31 – Automatic Compressor Staging

Buildings Impacted:
Power House

- Screw Compressor Efficiency Decreases Significantly below 60-50% of full-load capacity
- Currently, compressors staging is done manually
- All six compressors have capability to communicate w/ each other

Unit #	Manufacturer /Model	Size (hp)	Flow Capacity @ 100 psig (acfm)	Cooling Medium	Hours Operated Per Year ¹
1	Sullair / VCC200-100 HA	100	468	Air	3468
2	Sullair / VCC200-100 HA	100	468	Air	2745
3	Sullair / DS 13-100	100	450	Water	2913
4	Sullair / LS16-60H	60	268	Water	5201
5	Ingersoll Rand/ EP30	30	125	Air	3320
6	Sullair / LS16-60H	60	268	Water	5014

Note 1: Annual operating hours are based on 2007 data recorded by compressed air plant supervisor

Annual ECM Savings: \$7,578

ECM 32 – Compressor Heat Recovery

Buildings Impacted:
Power House

- Each air-cooled compressor generates heat at rate of 136,000 Btu/hr
- Three 500-cfm desiccant Dryers use heated air to regenerate desiccant Material
- 12 kW Electric heaters in each dryer are used to heat purging air
- Total displaced electric energy per year is 247,000 kWh

Airtek TWB-500 Desiccant Dryer

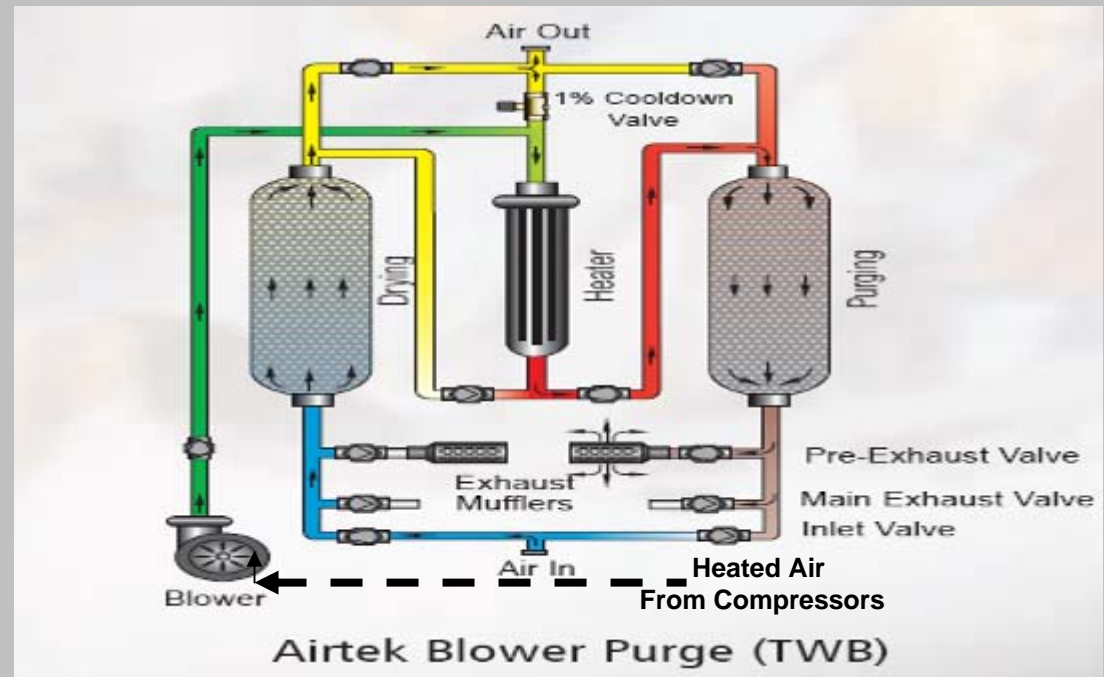

Annual ECM Savings: \$18,157

ECM 35 – Energy Awareness Program

- Pepco Energy will develop a new energy awareness program and educate employees and students
- Awareness and education lead to behavioral changes within the overall organization.

**Virginia Tech - 25,160,678
metric tons of CO₂ –
July 1, 2006- July 1, 2007**

Buildings Impacted:

McBryde Hall
Hahn Hall
Pritchard Hall
Dietrick Hall
Cassell Coliseum
Power House

Pepco Energy will work with Virginia Tech and Energy Star to determine the most advantageous use of program funds and savings may include:

- “Energy Manager” on-site
- An annual energy fair hosted by Pepco Energy
- A “focus on energy” component within the Virginia Tech campus
- Posters and advertising for Virginia Tech



Annual ECM Savings: \$23,734 for 5 buildings

ECM 36 - Metering

- Track Energy Consumption By Building
- Install Meters for Each Utility per Building
- Allows End User to Monitor Energy Consumed
- Maintenance Tool for benchmarking and looking for inconsistencies in usage
- Savings to materialize on other ECMs

Buildings Impacted:

McBryde Hall
Hahn Hall
Pritchard Hall
Dietrick Hall
Cassell Coliseum
Power House

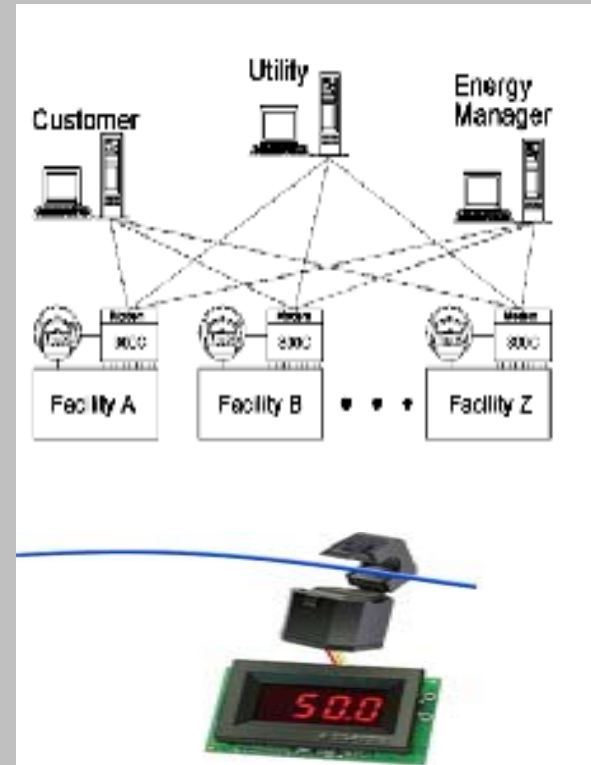

“You cannot manage what you cannot measure”

The VTCAC Resolution & Sustainability Plan

- VTCAC Resolution:
www.facilities.vt.edu/sustainability/climateAction.pdf
- Sustainability Plan:
www.facilities.vt.edu/sustainability/sust
- Office of Sustainability:
www.facilities.vt.edu/sustainability